

INCLUDED

Hex Wrenches **X1**

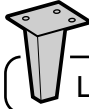

Legs **X6**



M6X25mm **X6**

Non Slip Pads **X6**

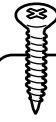
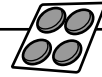

Woodscrews
4,2mmX19mm **X12**

ATTENTION! Choose left or right handed place for chaise
(this instruction shown how to assembly right handed chaise)

1

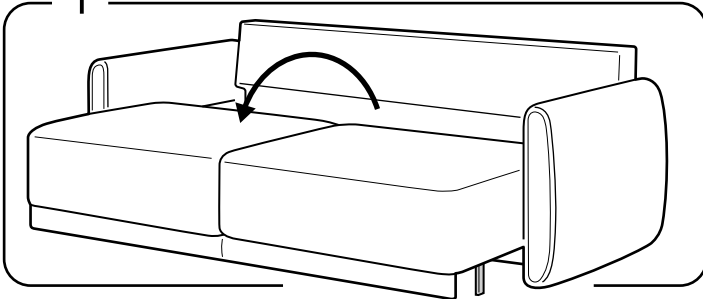

Open the mechanism completely.

2

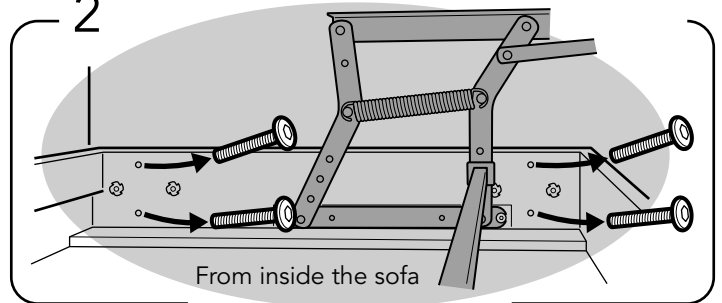

Remove 4 bolts from the right armrest.

3

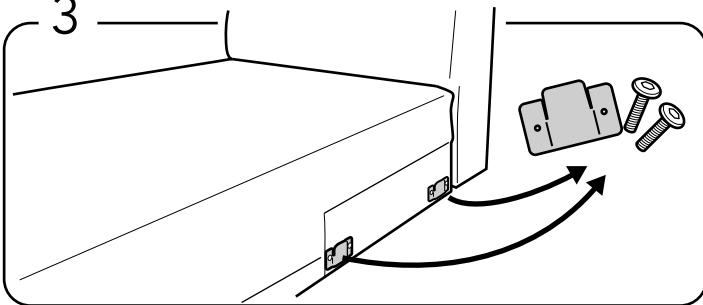

remove 2 bolts and 1 metal bracket from chaise and another from backrest of the chaise as in picture.

4

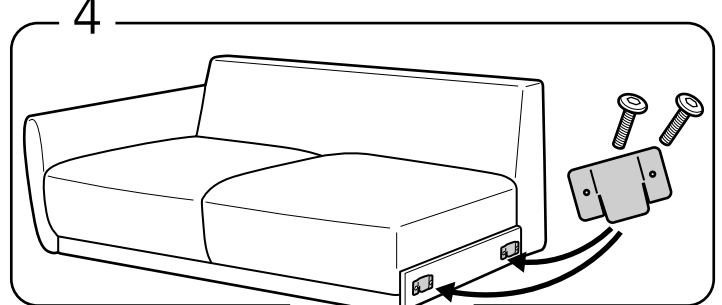

Attach previously unmounted metal brackets with M6 x 20 bolts to the sleeper chaise side.

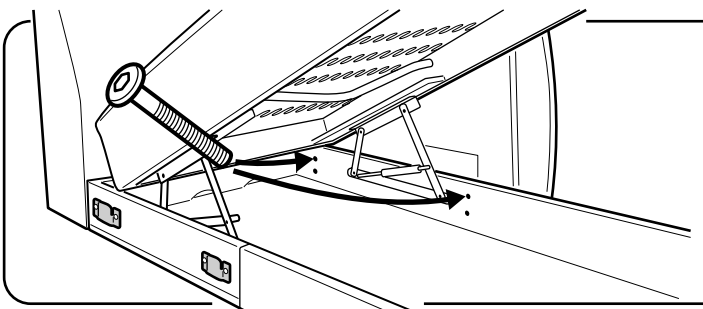

Fix the armrest first with four M6 x 55 bolts from inside the storage box.

5

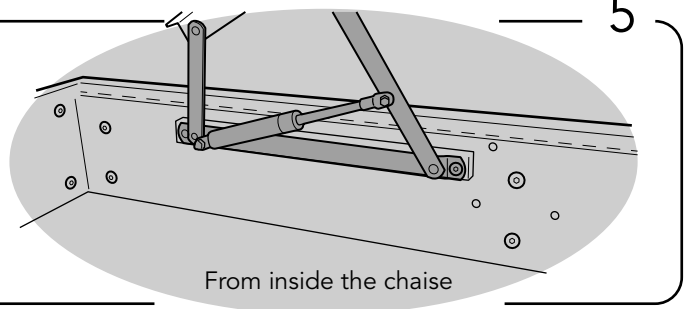

From inside the chaise

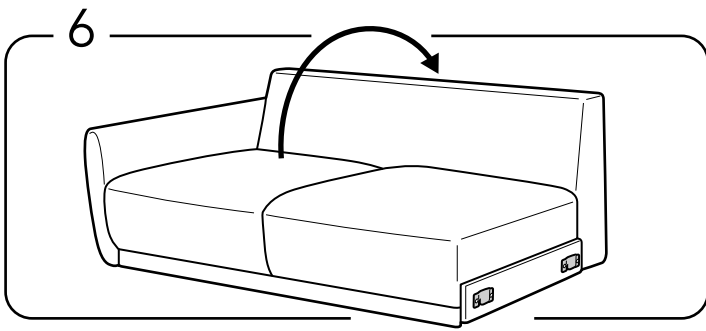

Turn the sofa to the backside.

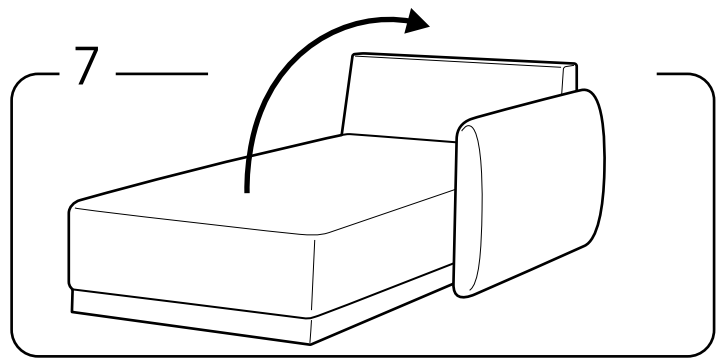

Turn the chaise to the backside.

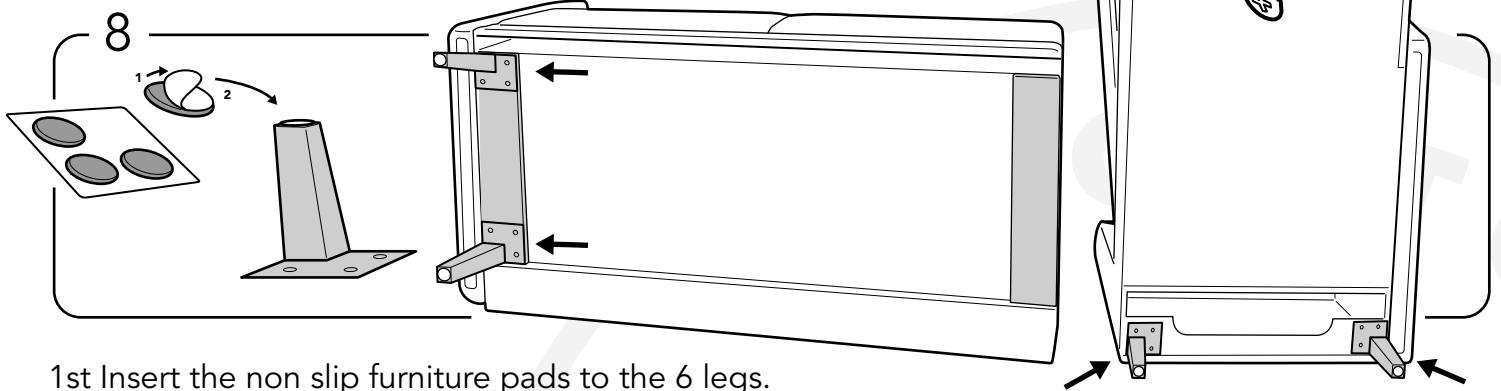

1st Insert the non slip furniture pads to the 6 legs.

2nd Attach each legs with the M6x25mm bolt to align the metal in place then use two screws on each leg.

3rd Turn the sofa and chaise back to the legs.

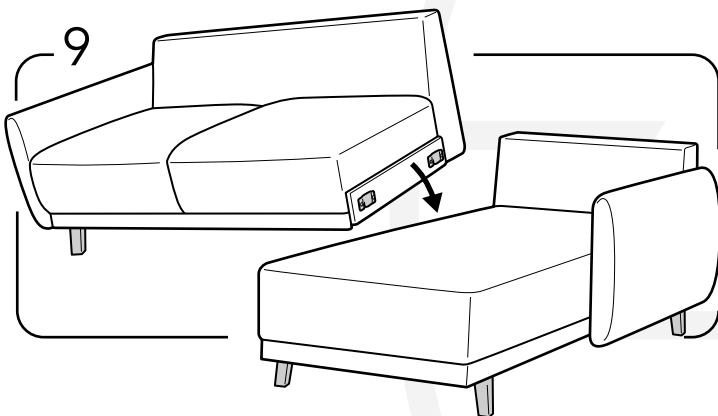

Attach the sleeper part with the chaise part as shown on picture. Be sure that the both metal brackets are attached correctly!

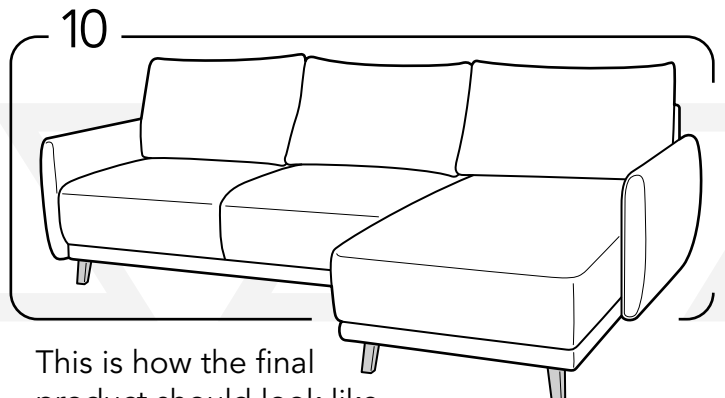

This is how the final product should look like.